

USGS Education - Paper Models Collection: The collection includes geologic processes, fossils, and landforms. They can be printed, colored, cutout and assembled. Printing on firm paper is helpful (model parts pages only.)

The Sand Dune model collection was created by Tau Rho Alpha, John P. Galloway, and Scott W. Starratt, USGS, Menlo Park CA. (Open File Report 98-131-A)

Sand Dunes - 6 models

Sand dunes can form different shapes depending on the kind of sand, wind direction, and environment. This set of models includes one dynamic model plus six different kinds of dunes: 1) dune migration, 2) Transverse 3) Oblique, 4) Longitudinal, 5) Barchan, 6) Star, and 7) Parabolic. The first model is a dynamic model that shows how sand moves up a dune (stoss side) and down its slipface.

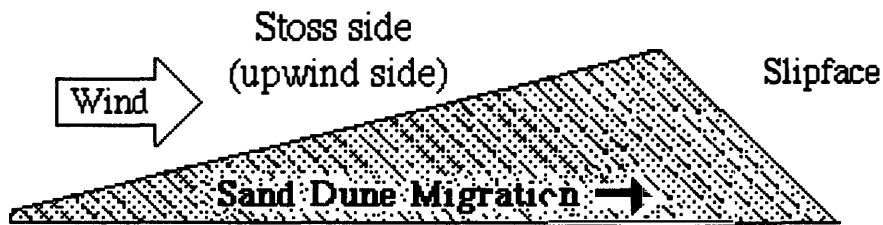

WHERE TO SEE MODERN AND ANCIENT EOLIAN (wind-blown sand) DEPOSITS

Modern Eolian Deposits

Algodones dune field, CA
Coral Sand Dunes State Park, UT
Death Valley National Park, CA
Indiana Dunes National Seashore, IN
Kelso Dunes, CA
Kobuk Dunes, AK
Sand Mountain, Highway 50, east of Fallon, NV
Oregon Dunes National Seashore, OR
White Sands National Monument, NM

Ancient Eolian Deposits (Sandstones that used to be sand dunes)

Arches National Park, UT
Canyonlands National Park, UT
Grand Canyon National Park, AZ
Valley of Fire State Park, NV
Zion National Park, UT

Glue

Back to models



Print This Card

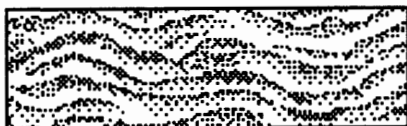

Pattern of dune migration. Model Sheet one of two.

Glue this

on the reverse side of this.

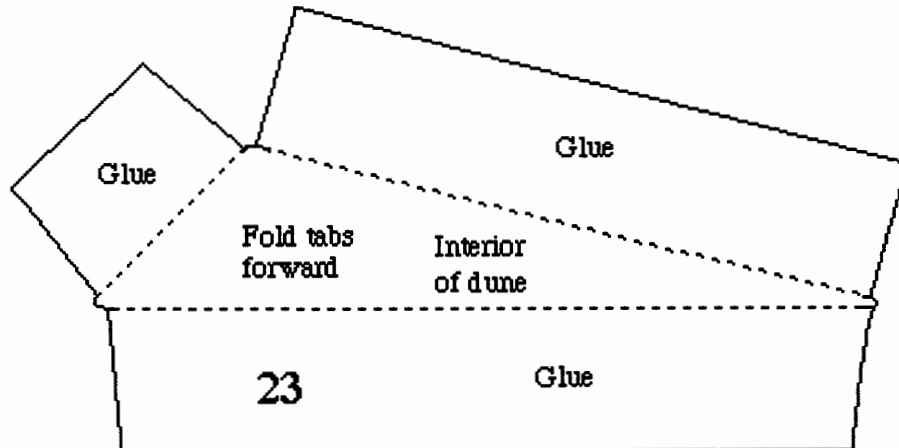
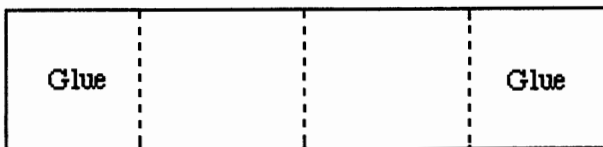
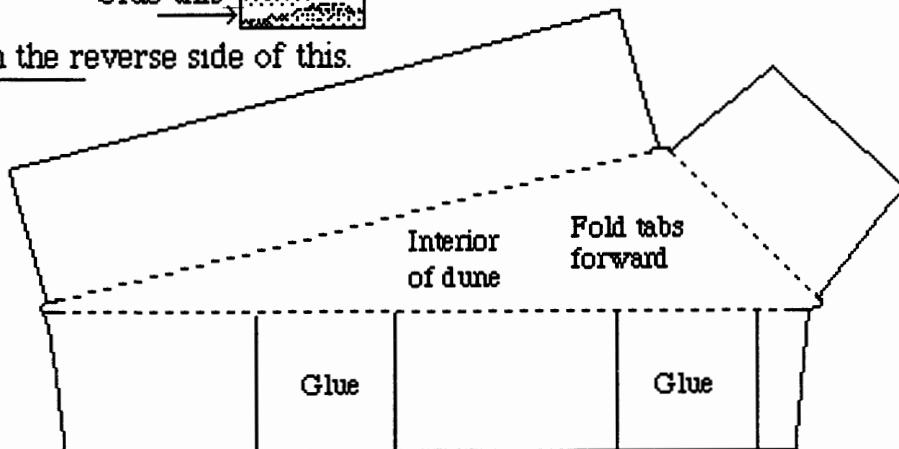

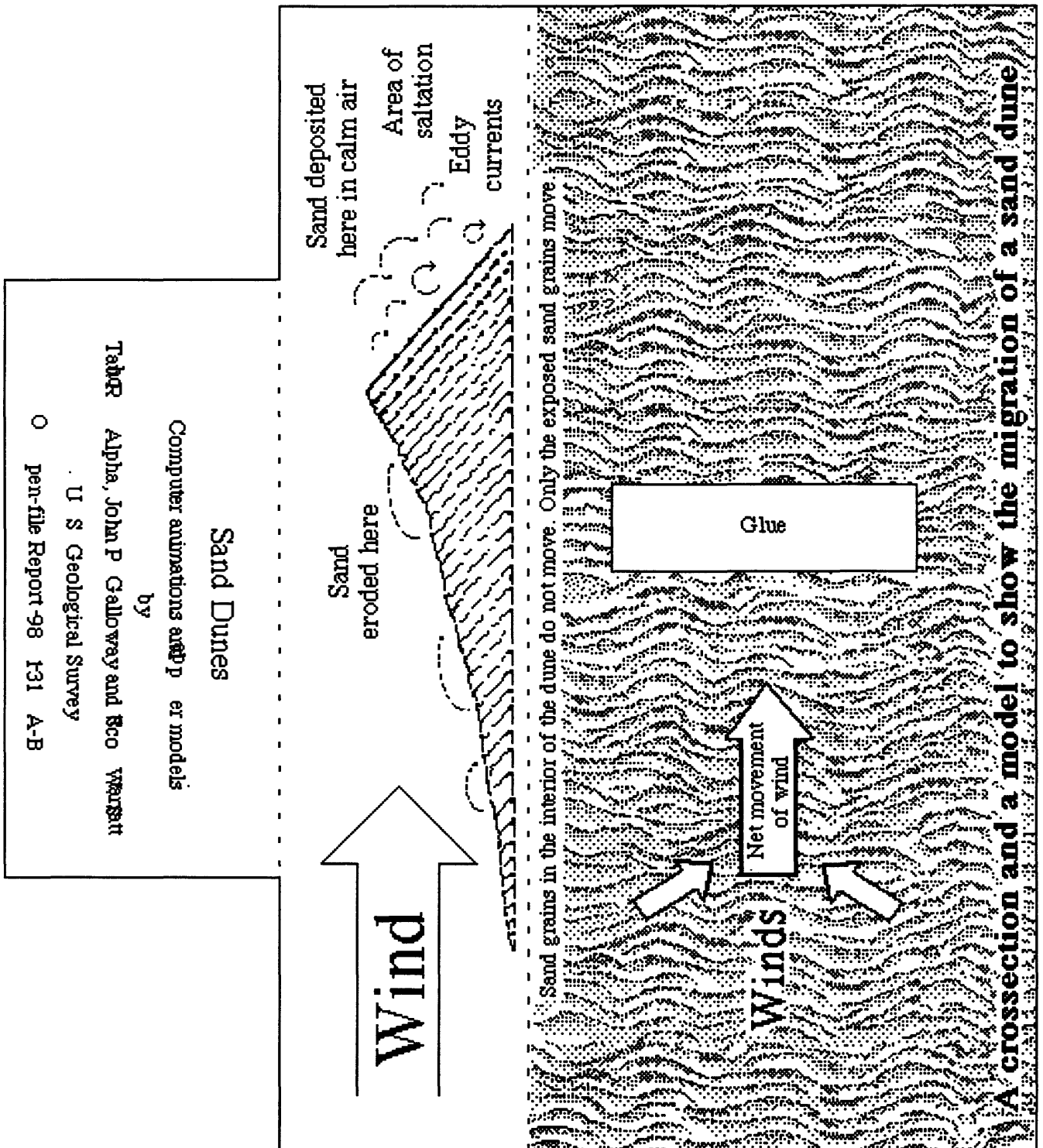

Step 1: Cut out then fold model and base.

Strip

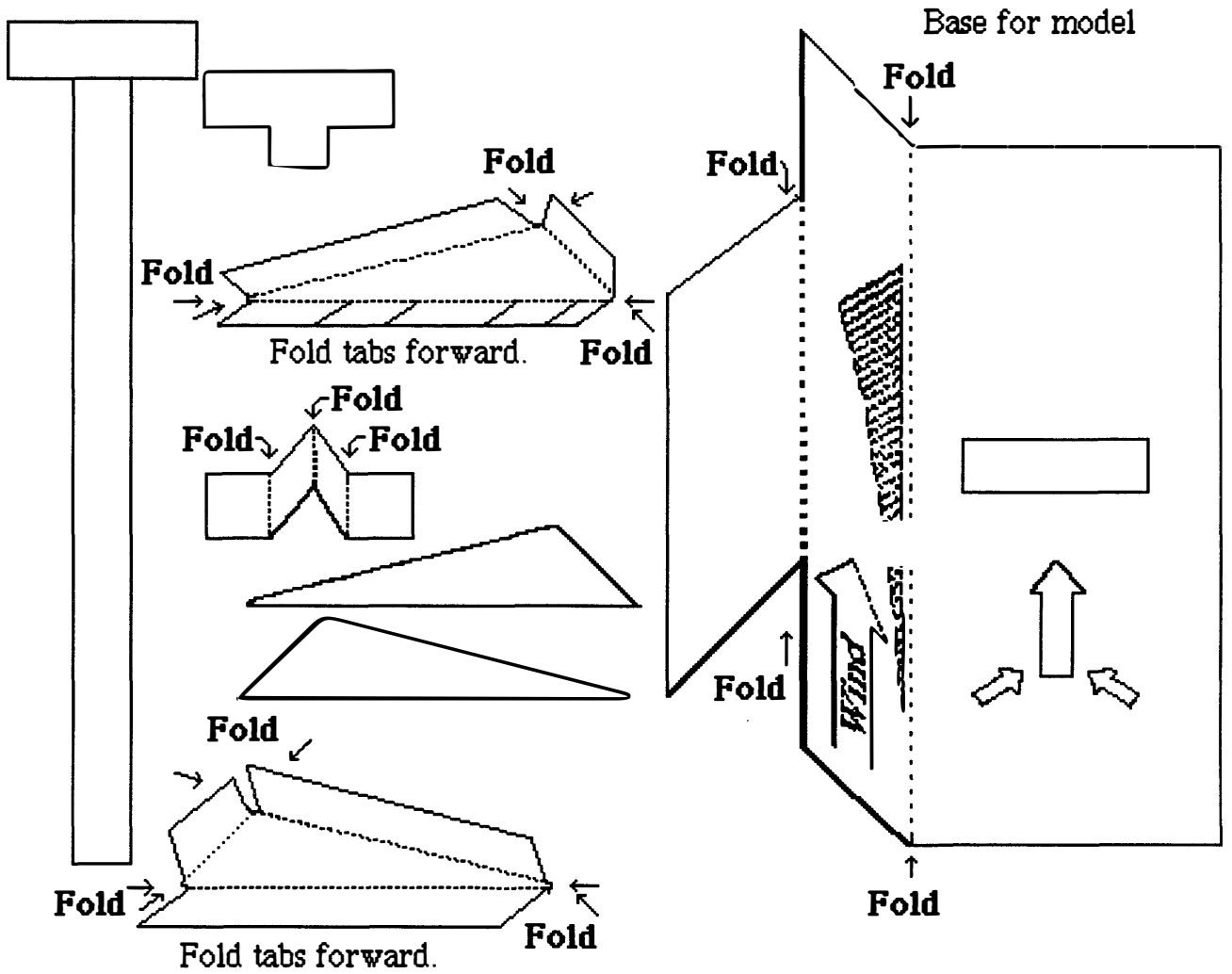

Step 2: Build the dune. Fold the strip into the "tent" shape and glue to the marked spaces. Fold the dune and glue. Add the two triangle shaped outsides to the finished dune.

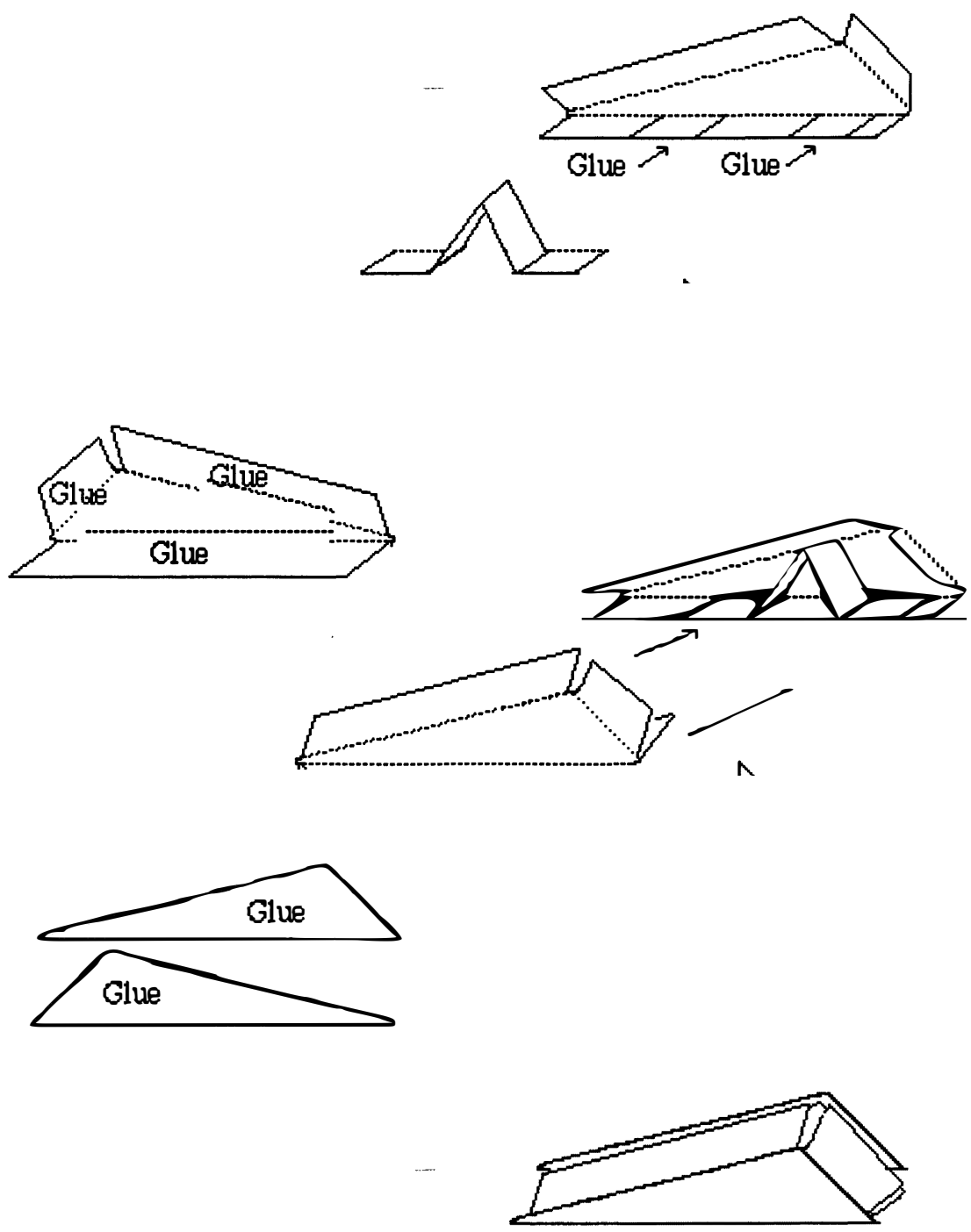

Step 3: Build and curl the Sand Strip. Glue the T to the back of the strip. Curl the strip. The more the strip is curled, the better the model works.

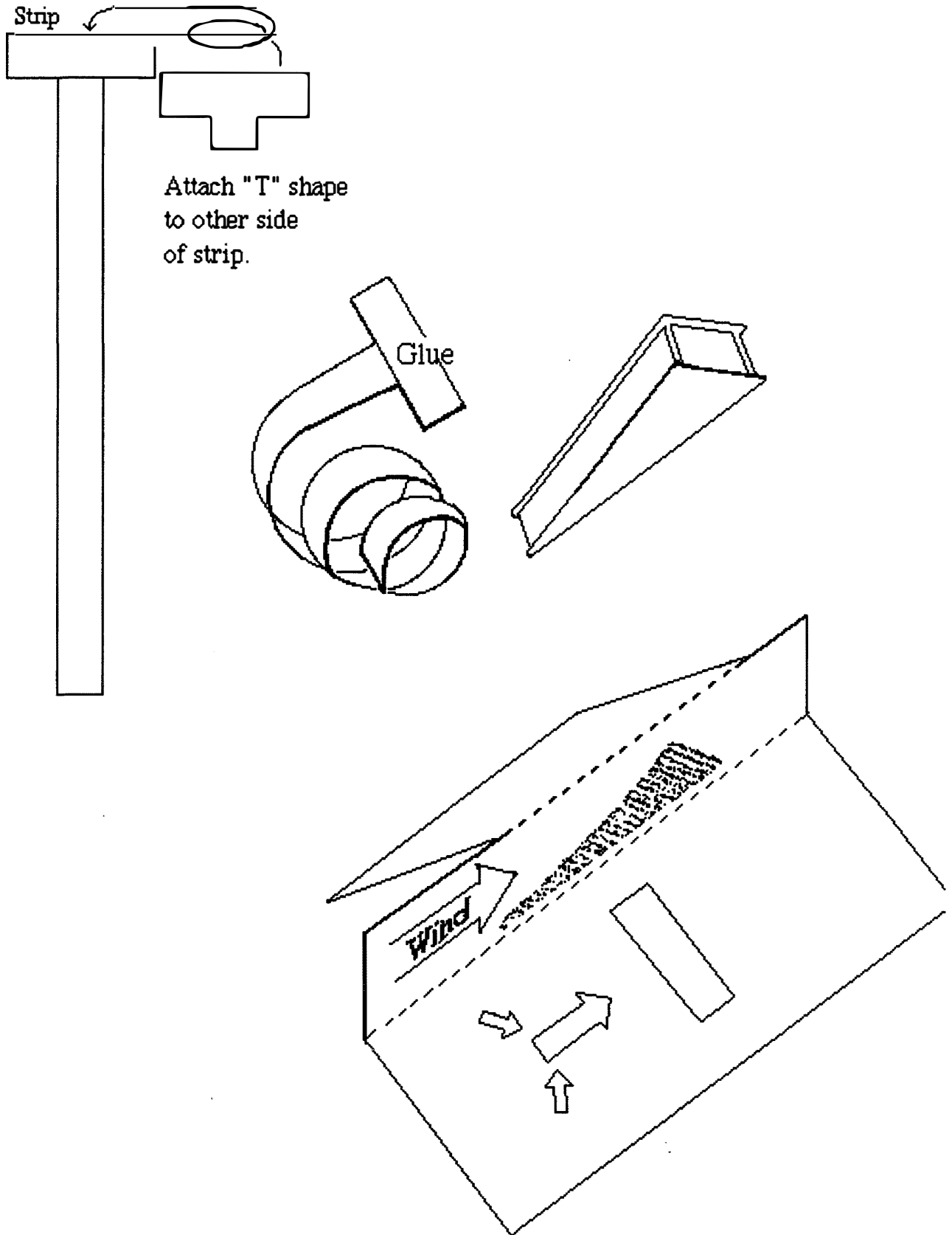

Step 4: Glue the strip to the base at the marked spot. Place the dune on top of the strip so that it curls up over the narrow end. Now as you slide the dune to the right, the sand will climb up the dune slope.

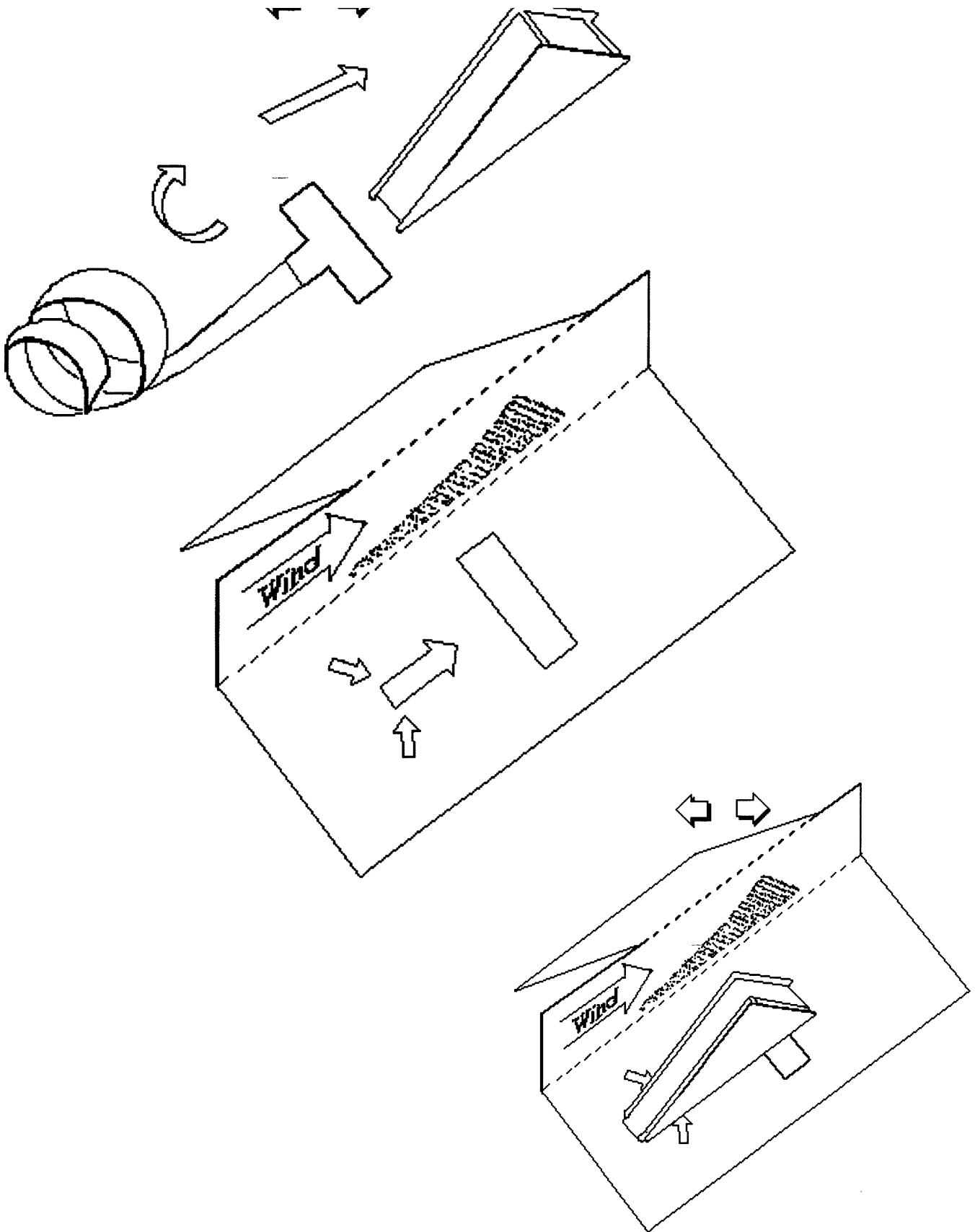

Model 2 - Transverse Dune

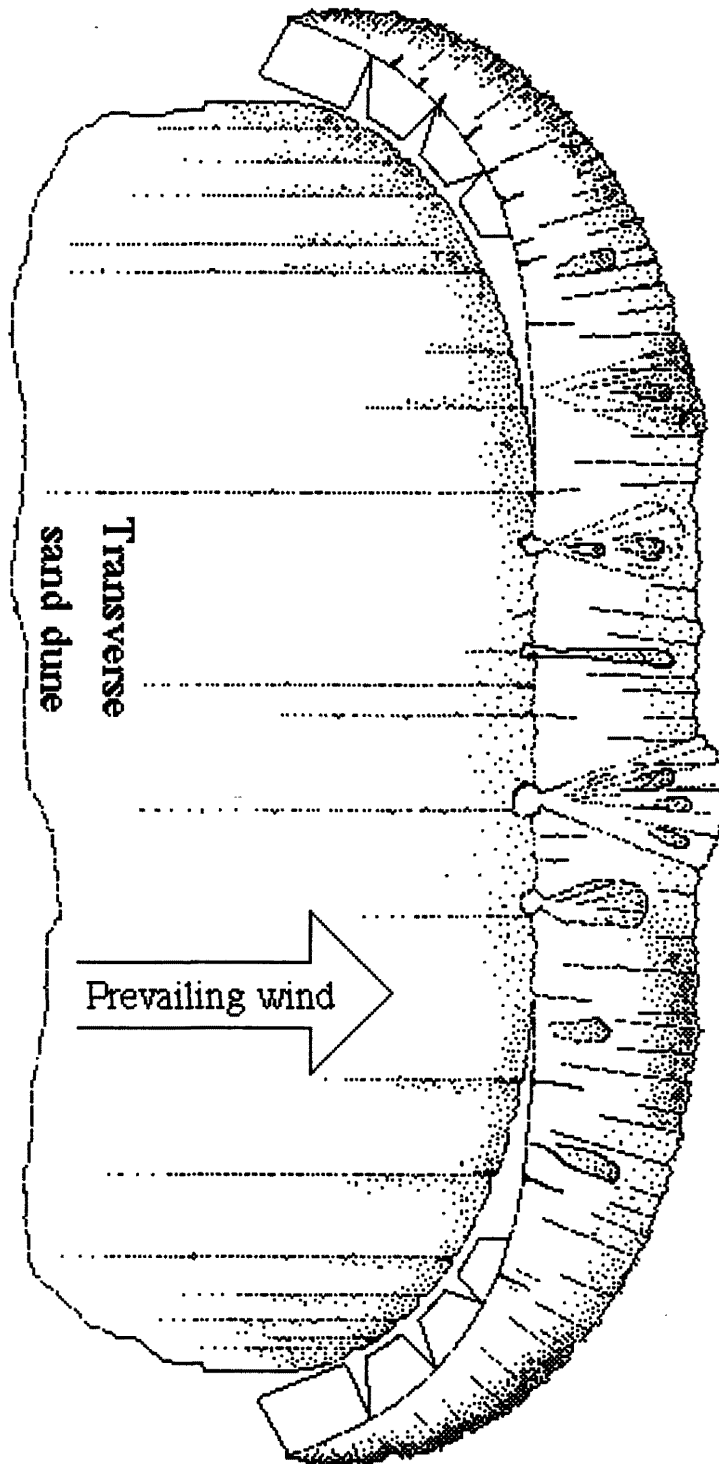

Transverse dunes occur where there is a plentiful supply of sand. Transverse dunes form straight to very gently curving ridges. The dunes are aligned perpendicular to the prevailing wind. The winds that form transverse dunes usually come from 75 to 90 degrees to the dune axis. There is a close relationship between the dune height, width and spacing of transverse dunes. Sediments of transverse dunes blow up the dune from the wind direction, and are deposited on the slopeface, as the model shows. The dune migrates downwind. Transverse dunes represent approximately 40 percent of the dunes found in the sand seas world wide.

To complete the model, cut out, fold, and glue the tabs.

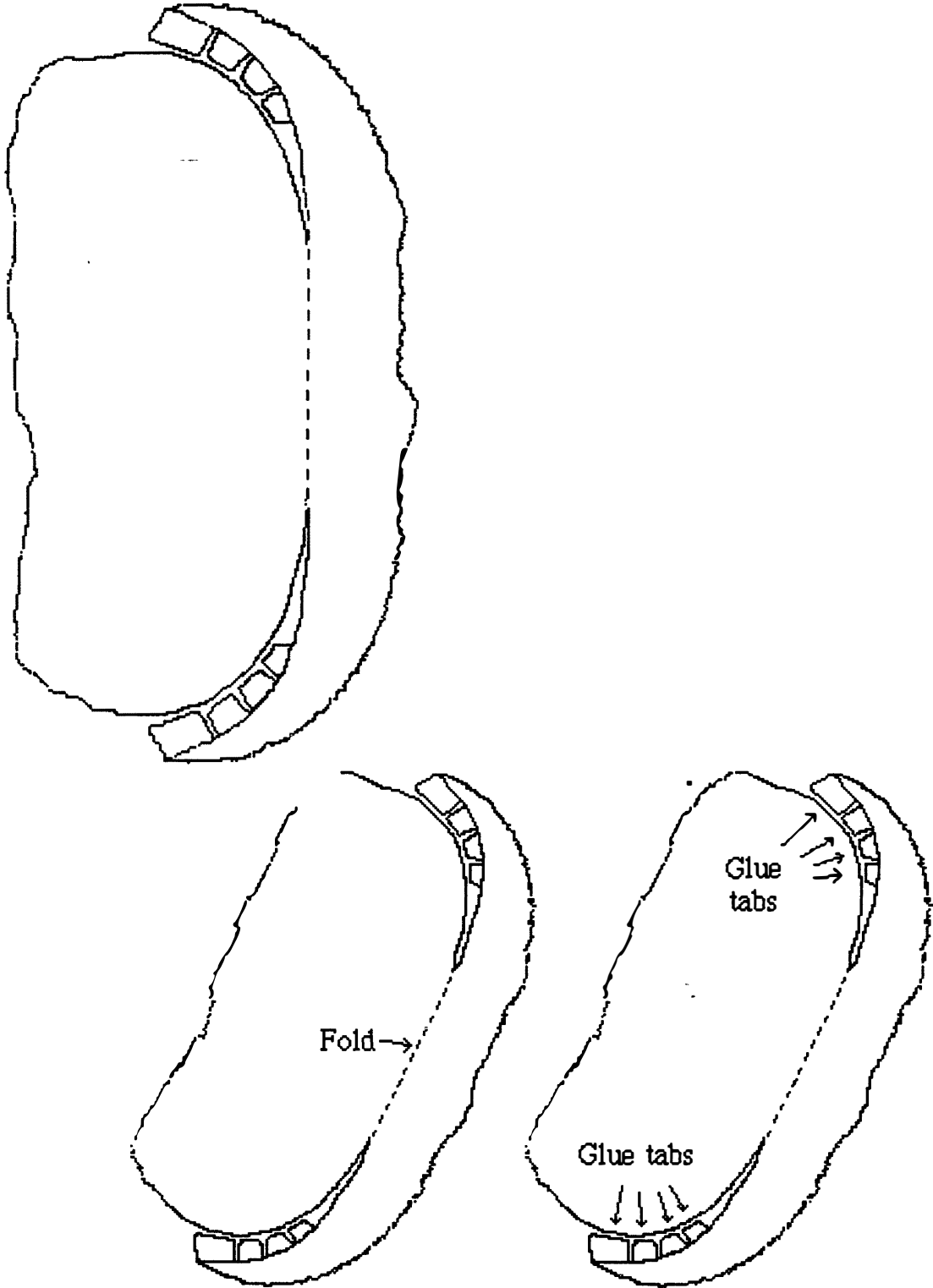

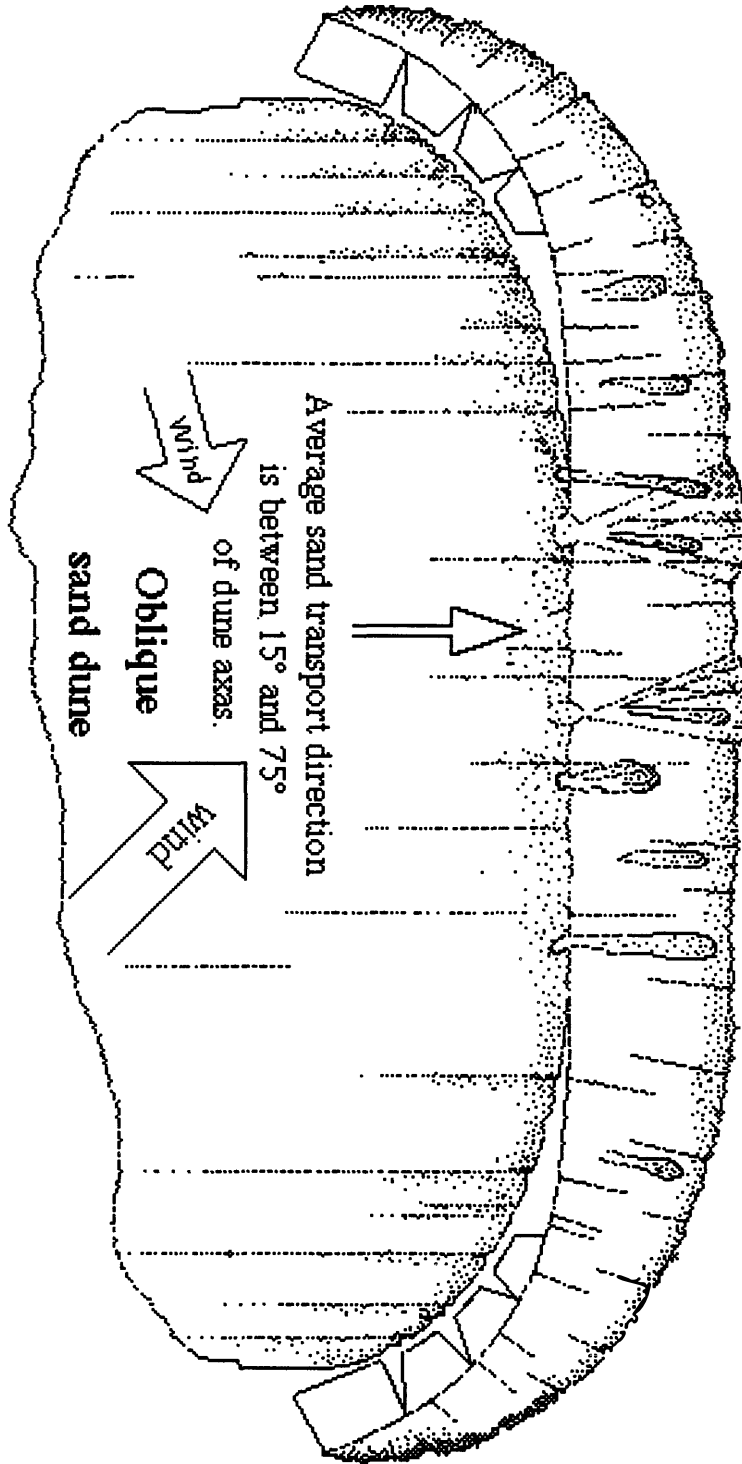

Model 3 - Oblique Dune

Oblique dunes are similar to transverse dunes in that they form straight to very gently curving ridges. The winds that form oblique dunes come from two directions usually 15 to 75 degrees to the dune axis. One of the wind directions is usually dominant (indicated by the larger arrow on the paper model) which results in a sand transport vector at an angle to the axis of the dune.

To complete the model, cut out, fold, and glue the tabs.

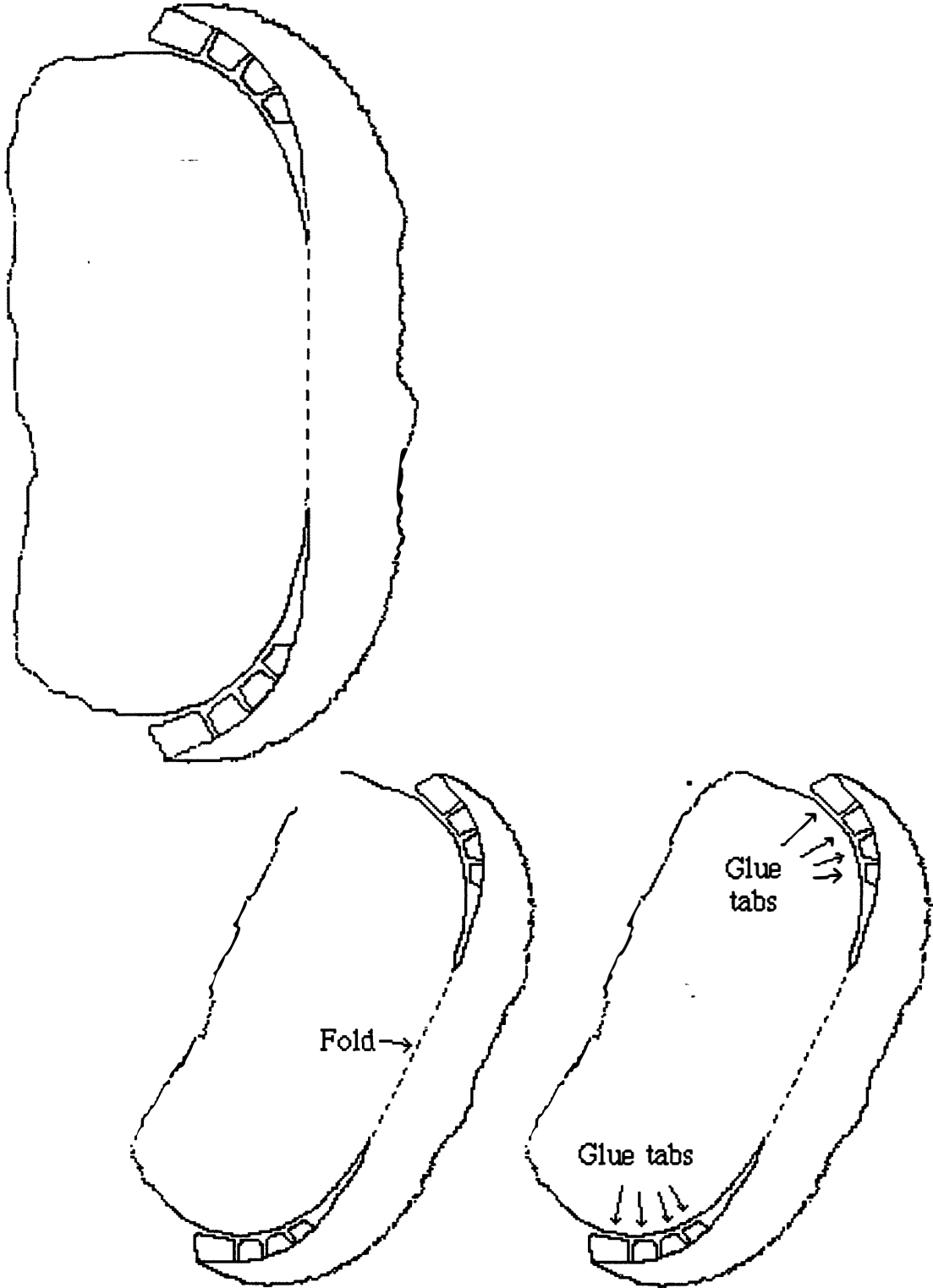

Model 4 - Longitudinal Dunes

Longitudinal dunes are formed in areas of limited sediment supply but with strong winds. The long dune crests are elongated parallel to the direction of wind flow. The winds that form longitudinal dunes come from two slightly different directions usually 0 to 15 degrees to the dune axis. Longitudinal dunes called seif dunes (Arabic for 'sword') are usually less than 4 meters high but can extend downwind for several kilometers. In large deserts they can reach a height of a 100 meters and extend for 120 km.

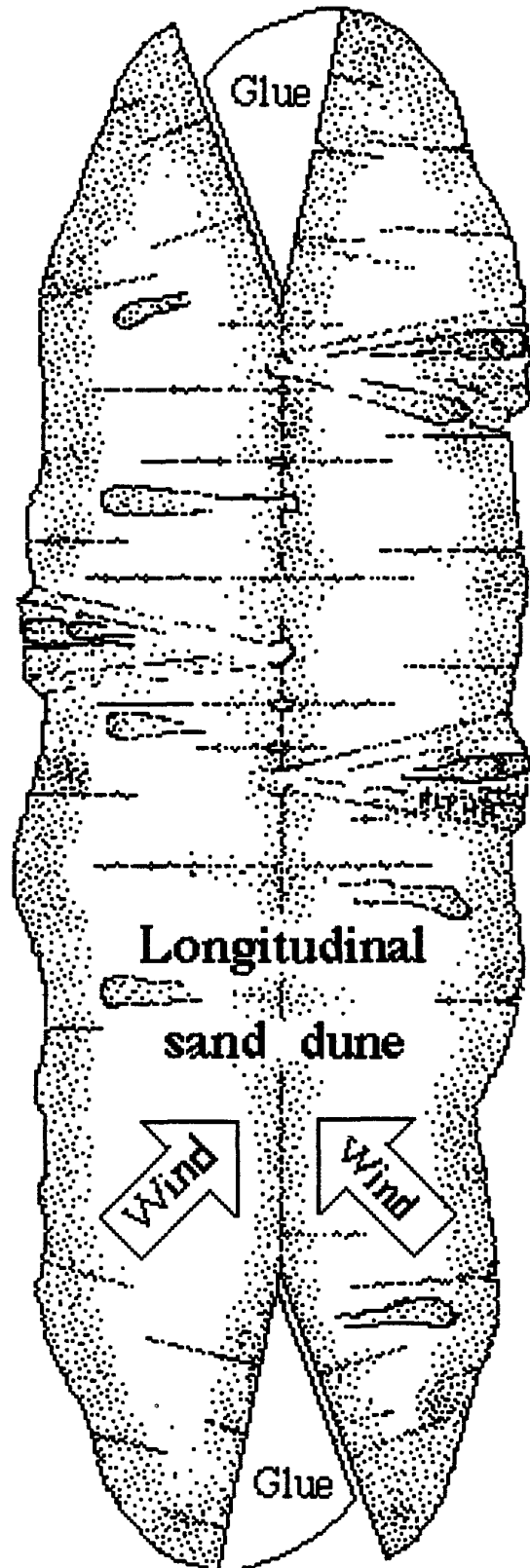

Model 5 - Barchan Dune

In the absence of vegetation, small individual crescent shaped dunes called barchan dunes are the dominant dune type. The wind regime is characterized by a narrow range of wind directions nearly perpendicular to the crescent. Barchans occur as isolated dunes in areas of limited sand availability. Barchans are characterized by a crescent shape in with a concave slip face and 'horns' extending downwind. Most barchans range in height between 3 and 10 meters. Dune height is typically 1/10th of the dune width. As the sand supply increases barchans can coalesce laterally to form transverse dunes. Barchans comprise only a small percent of global sand sea deposits.

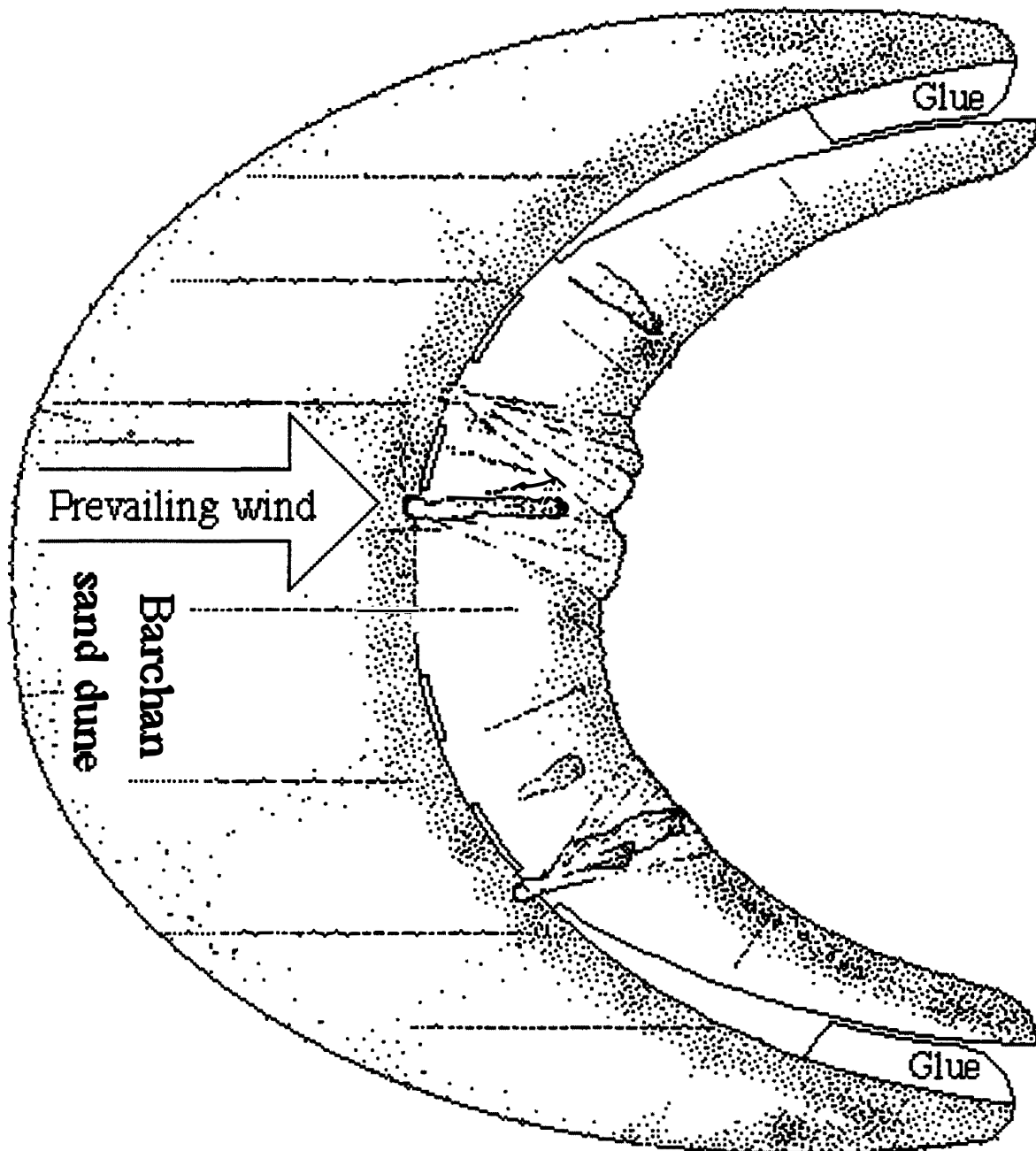

Be sure to cut the slots to help with the folding of this model.

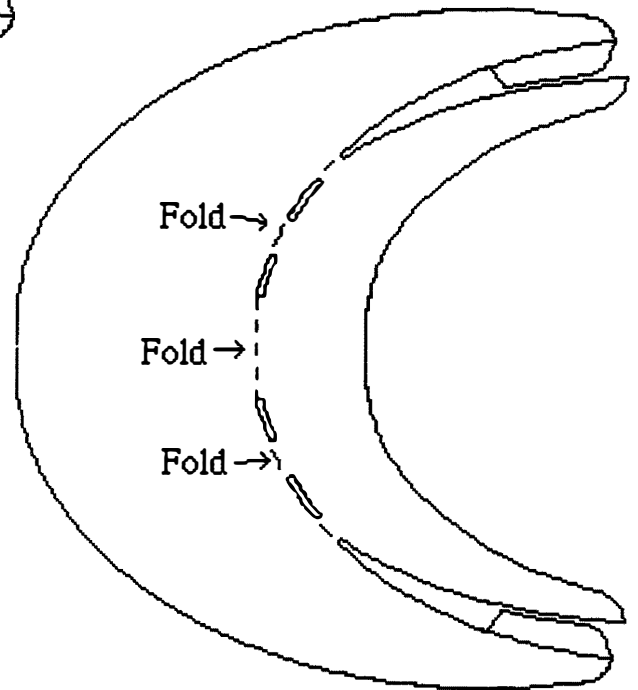
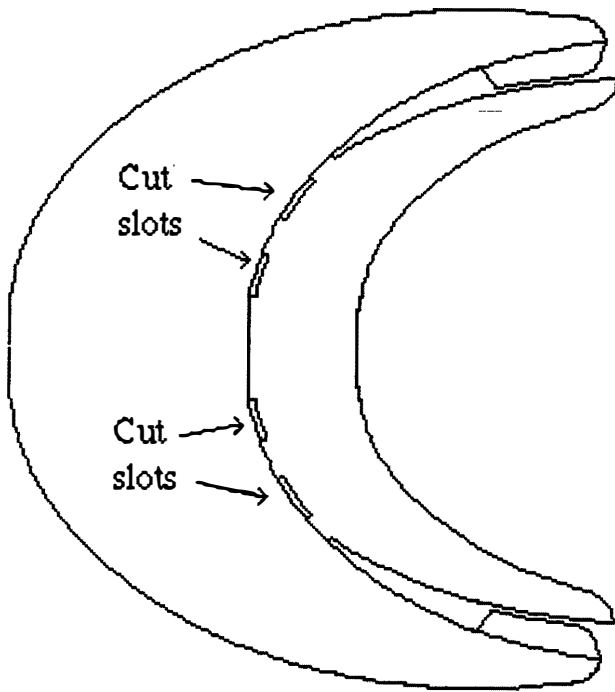

Model 6: Star Dune

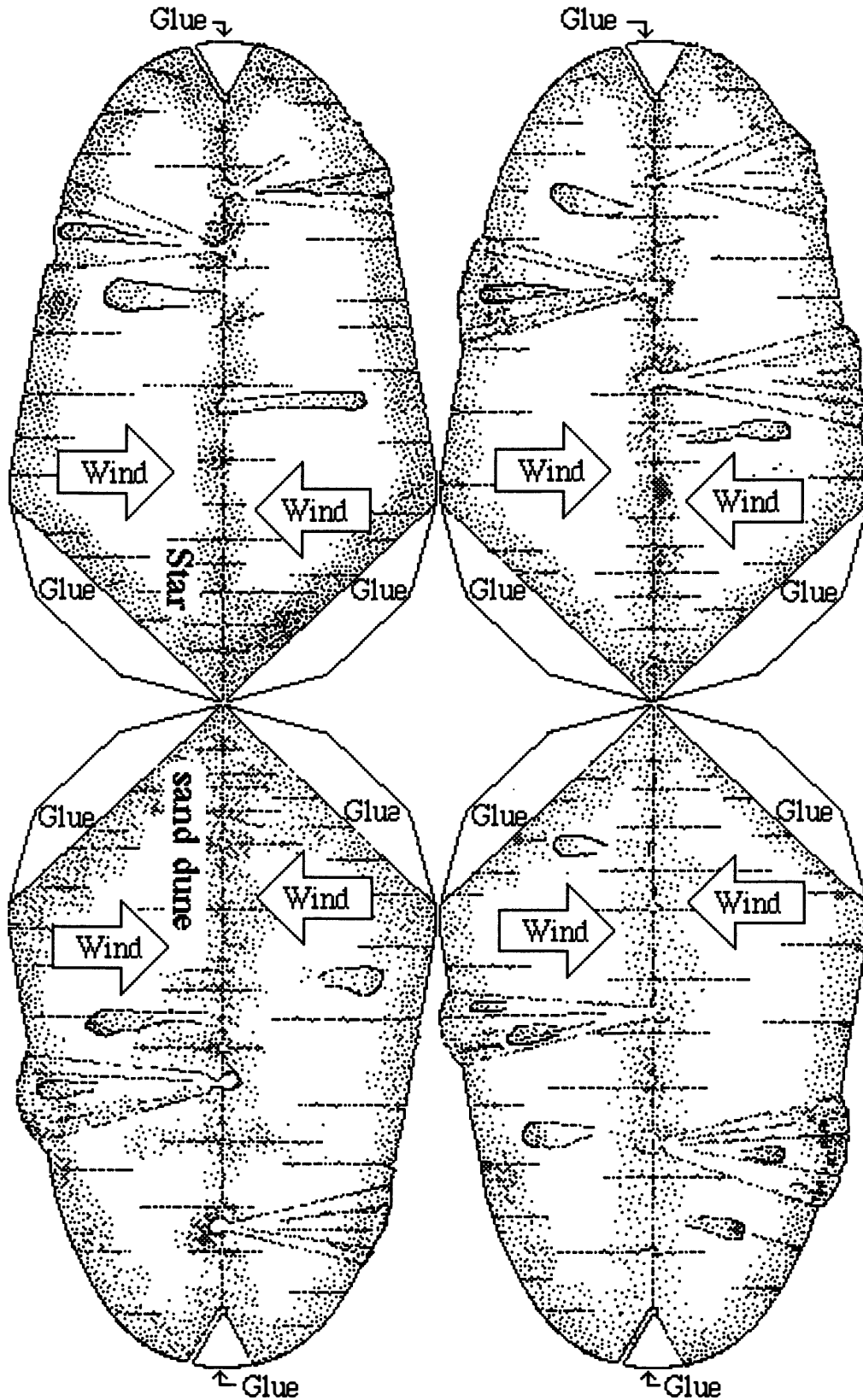

Star Dune

Star dunes are characterized by their large size, pyramidal morphology and radiating sinuous arms. The basal parts of star dunes consist of a broad, gently sloping (5-10 degrees) plinth or apron. They are the largest dunes in many sand seas and may reach heights of more than 300 m. They contain a greater volume of sand than any other dune type and occur in areas which represent depositional centers. Approximately 8.5 percent of all dune types are star type.

Star dunes are associated complex wind patterns coming from many directions. Star dunes are characterized by a pyramidal shape, with three or four arms radiating from a central peak and multiple avalanche faces. Each arm has a sharp crest, with avalanche faces which alternate in aspect as wind directions change seasonally. The arms may not all be equally developed and many star dunes have dominant or primary arms on a preferred orientation. The upper parts of many star dunes are very steep with slopes at angles of 15-30 degrees. Avalanche face orientation changes seasonally. Many of the claims for the 'world's highest dunes' are related to star dunes.

Step 1: cut out the four arms of the star dune.

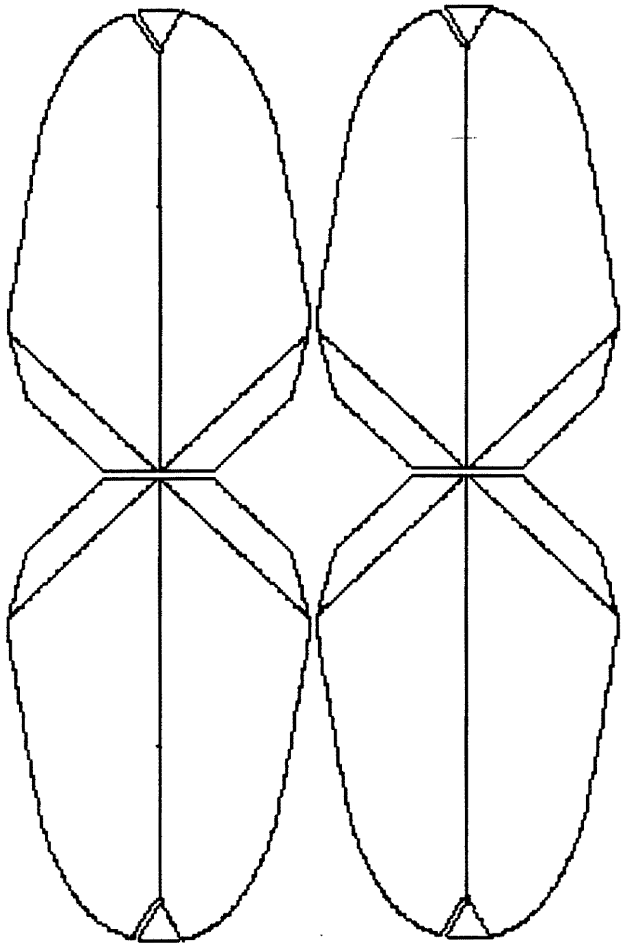

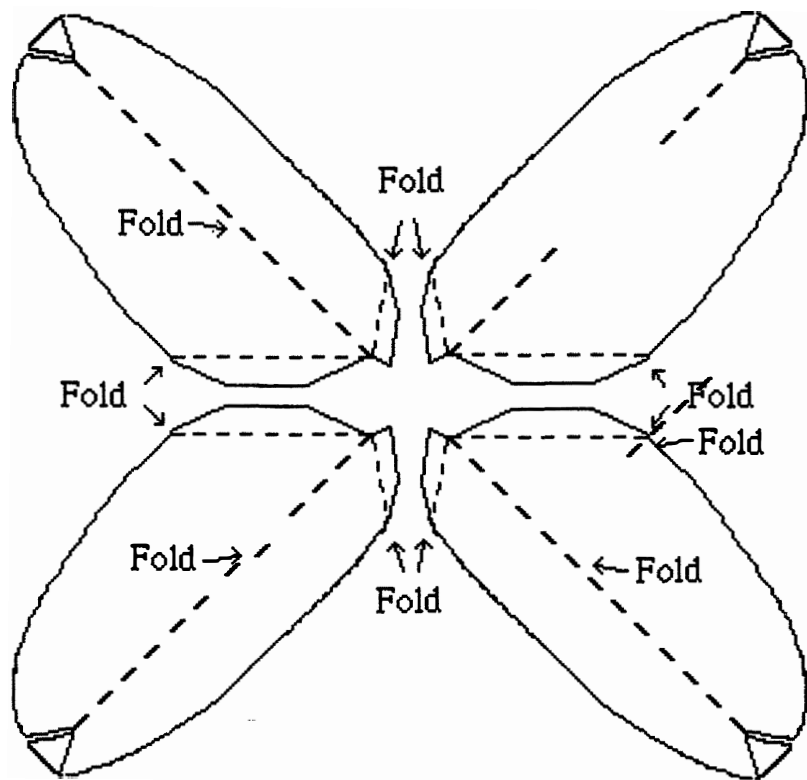

Step 2: fold and glue the four star arms as shown.

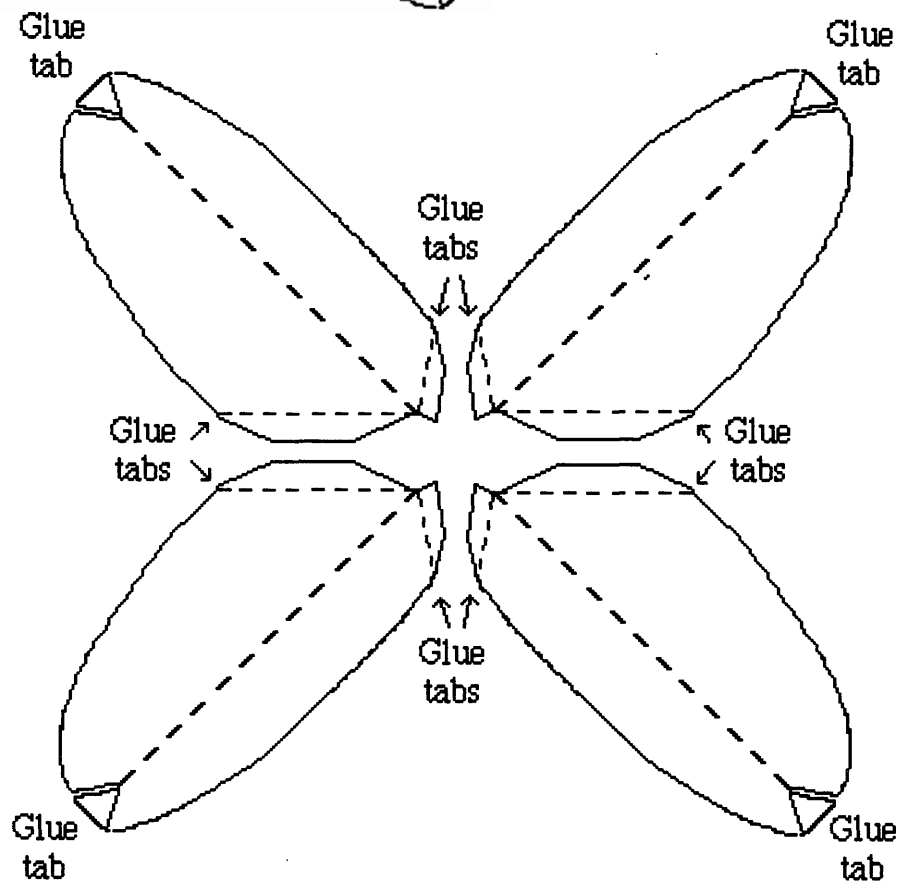

Model 7 Parabolic Dune

Parabolic dunes are common in many coastal and semi-arid environments. Parabolic dunes are characterized by a U-shape with trailing partly vegetated parallel arms, and an unvegetated active 'nose' or dune front that advances by avalanching. The conditions under which parabolic dunes form are not well known. They seem to be associated with the presence of a moderately developed vegetation cover, and with wind from one direction. The wind forms a blow out and the sand is carried up the stoss slope. A parabolic dune resembles a barchan dune but its 'horns' point the opposite direction --upwind. The ends of the dune may be anchored by vegetation.

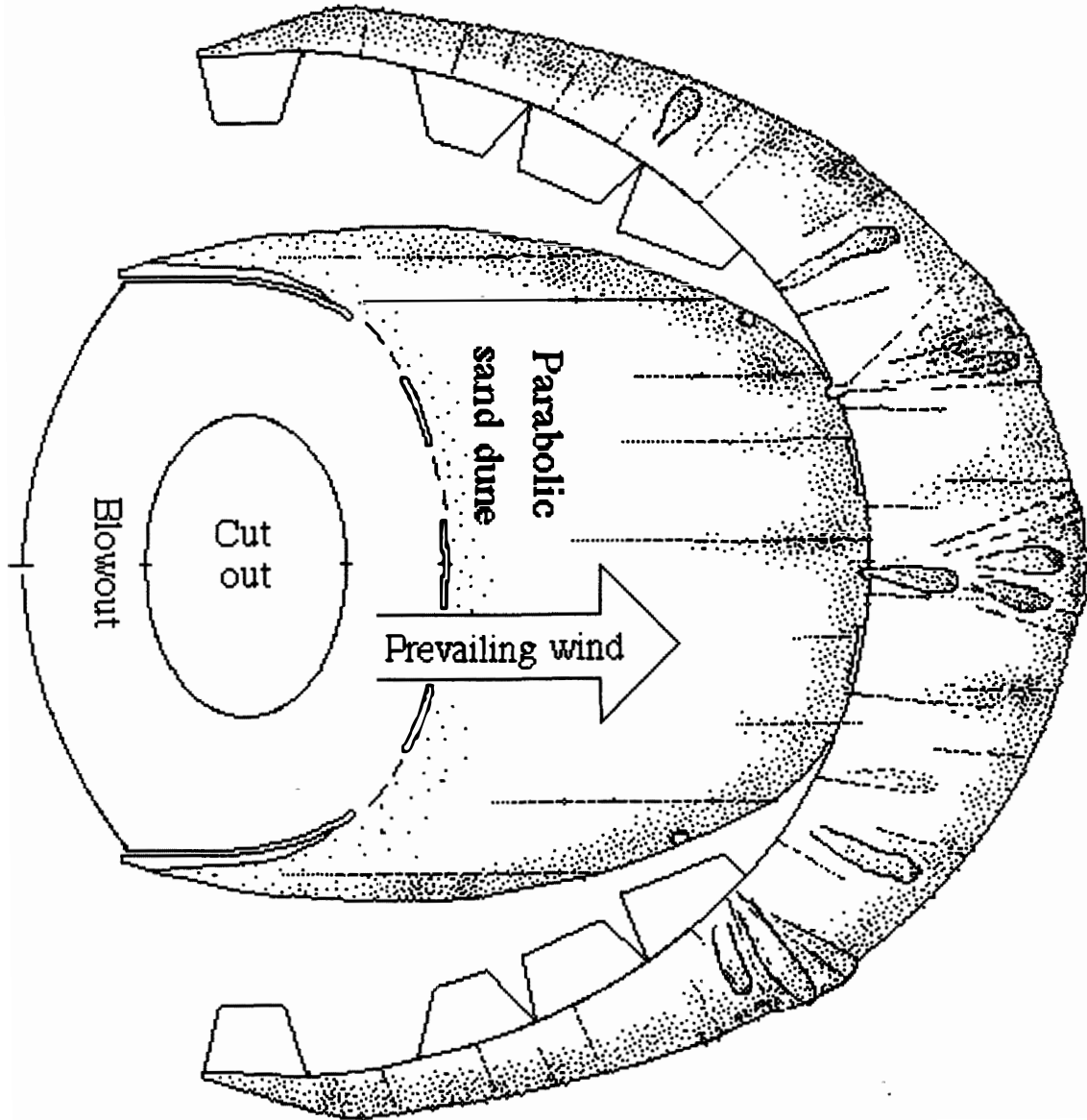

Cut out, fold, and glue model.

